

الفصل السابع

تعديل الرسوم

MODIFY DRAWINGS

Modify
<u>P</u>roperties...
<u>M</u>atch Properties
<u>O</u>bject ▶
<u>E</u>rase
<u>C</u>opy
<u>M</u>irror
<u>O</u>ffset
<u>A</u>rray
<u>M</u>ove
<u>R</u>otate
<u>S</u>cale
<u>S</u>tretch
<u>L</u>engthen
<u>T</u>rim
<u>E</u>xtend
<u>B</u>reak
<u>C</u>hamfer
<u>F</u>illet
<u>3D</u> Operation ▶
<u>B</u>oolean ▶
<u>E</u>xplode

Modify 1-7

Erase
 Break
 Divide
 Trim
 Copy
 Array
 Offset
 Mirror
 Extend
 Move
 1-7 Modify

2-7 Modify II Modify

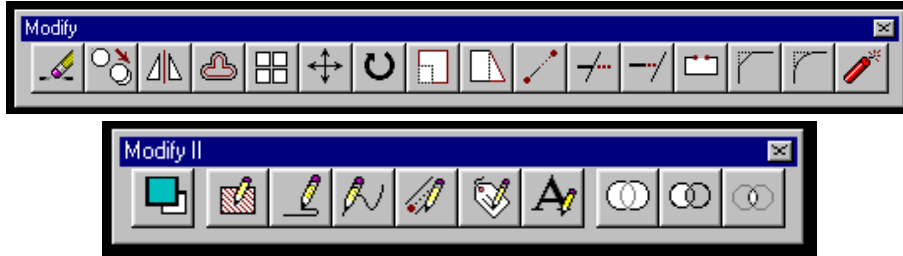

Modify II Modify

2-7

أولاً : طرق اختيار عناصر الرسم Selection of Objects

:

الاختيار بمربع الاختيار:

Shift

:

Select Objects:

Select

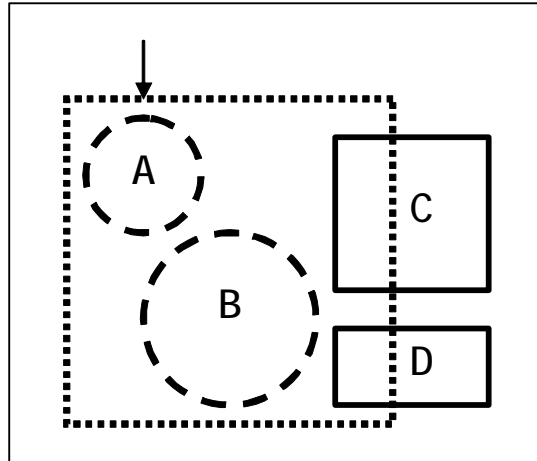

3-7

الاختيار بالنافذة Window :

W

Window

Select object

B A

3-7

الاختيار بتقاطع الإطار Crossing :

C Crossing

Crossing

.4-7

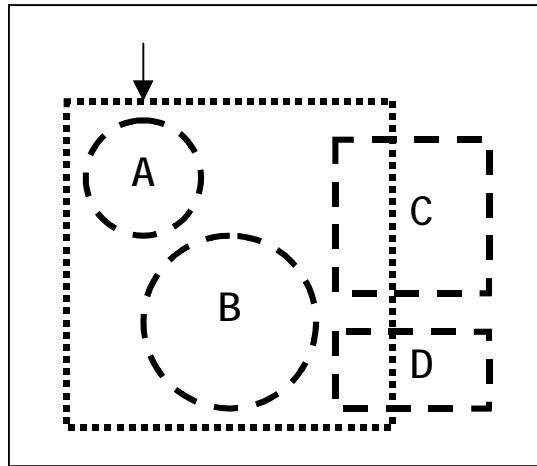

4-7

الاختيار بالآخر Last :

(L)

Last

الاختيار بالسابق : Previous

Previous

(P)

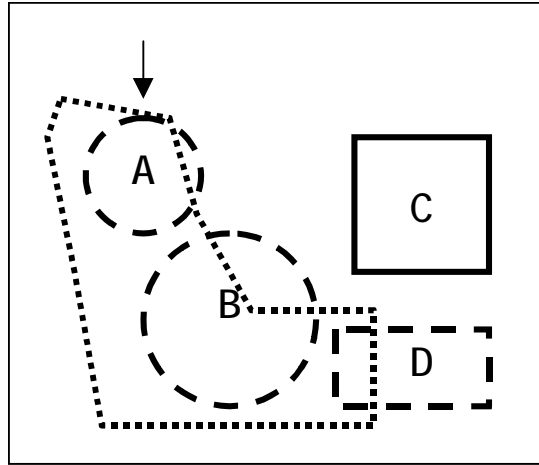

Fence

5-7

الاختيار بالقاطع : Fence

5-7

Fence

F

Fence

()

Add Remove Add
Add Remove

Shift

Shift

لا: المحو والإزالة والقطع:

المحو Erase

إصدار الأمر:

Delete

Enter

Erase E

E ERASE

.Modify

Erase

.MODIFY

Erase

:

COMMAND : ERASE
SELECT OBJECTS :
SELECT OBJECTS :

Enter

COMMAND :

Erase

تمرین 7-1:

```

Command:Line
From Point:
To Point
To Point

Command:
Select objects :
Select objects : Enter

Command Erase
Command

```

W

.Enter All

تمرین 7-2:

```

Command Erase
Select objects : W

First corner :
Second corner :
Select objects : Enter

Command:
Command: Erase
Select objects : All
Select objects : Enter

Command

```

Undo

U

Undo

Erase

Undo

"standard tool bar "

.Edit

Break مسح جزء من عنصر الرسم

Break

.4-7

Break

إصدار الأمر:

Br

Break

0

Modify

Break

Modify Toolbar

Break

•

•

•

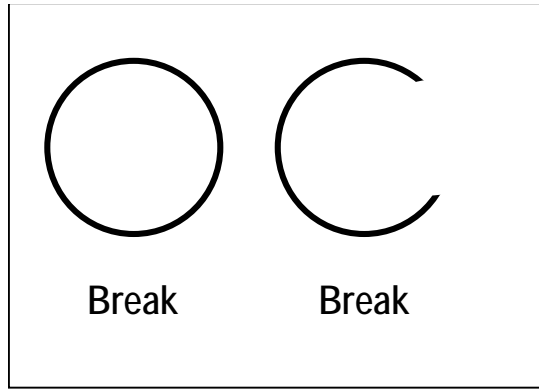

Break

6-7

Break

:

Command : Break or Br

Select objects :

:

:_____

Enter second point (or F for first point):

:

F

Enter second point (or F for first point) : F

Enter first point

Enter second point :

Command:

ثانياً: أوامر النسخ:

النسخ Copy

Multiple

إصدار الأمر:

Copy

0

Co

Modify

Copy

Modify Toolbar

Copy

:

Command: Copy
Select objects

Select objects

< Base point or displacement > / Multiple

Second point of displacement :

Command:

: M
 <Base point or displacement > / Multiple : M

Second point of displacement

Second point of displacement

-

Second point of displacement

Command :

تمرین 7-3:

. Copy
 Command Copy
 Select object :
 <Base point or displacement>/Multiple CEN of
 Second point of displacement

تمرین 7-4:

Command Copy
 Select object :
 < Base point or displacement > / Multiple : M

Base point : CEN of

Second point of displacement

Second point of displacement :

Second point of displacement:

Command :

MIRROR العكس بالمرآة

إصدار الأمر:

Mirror

0

Mi

Modify

Mirror

. Modify Toolbar

Mirror

•

•

•

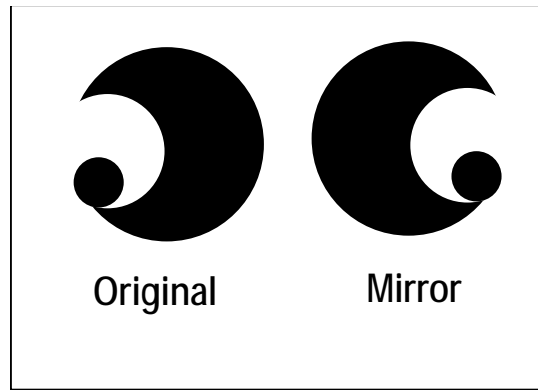

Mirror

7-7

:

command : Mirror
select objects :

Select objects :

First point mirror line :

Second point of mirror line

-

Delete old objects ? <N>

N

Y

.Enter

تمرین 5-7:

Command Mirror
Select objects : C
First corner :

Second corner : Select objects : First point of mirror line : Second point of mirror line : Delet object ? < N > N or Y Command
--

التحريك MOVE

Copy

Copy

Move

إصدار الأمر:

.Enter

M

Move

•

Modify

Move

•

. Modify

Move

•

:

Command: Move

Select object:

-

Select object :

Base point or displacement :

Second point of displacement :

:

1 - النسخة في صفوف وأعمدة Rectangular :

0

:

Command : Array
Select objects :

-

Select objects :

-

Rectangular or polar array (R/P) R
Number of rows (-) < /> :

Number of columns (II):</>

-

Unit cell or distance between row(_ -)

-

-

-

تمرين 7-7:

Command : Array
 Select objects : Select point P1 on circle C1
 Rectangular or polar array (R/P) R
 Number of rows (-) < />2 :
 Number of columns (III) < />3 :
 Unit cell or distance between rows (-) : -4
 Distance between cohms (III) : 3
 Command :

ب النسخة على محيط دائرة او قوس Polar Array

.

0

:

Command Array
 Select objects :

Select objects :

Rectangular or polar array (R/P) P
 Center point of array :

Number of items:

Angle to fill (+ = ccw - = cw) < 360 > :

(360

)

Rotate objects as they are copied ? Y

Y

N

تمرين 7-8:

Command : Array
 Select objects :
 Rectangular or polar array (R/P) P
 Center point of array :7,7
 Number of items:8
 Angle to fill (+ = ccw - = cw) < 360 > :
 Rotate objects as they are copied ? < Y >
 Command :

النسخ على صورة متوازية OFFSET

Offset

. spacing

إصدار الأمر:

	:	offset	
.Enter	0	offset	•
	Modify	offset	•
. Modify		offset	•

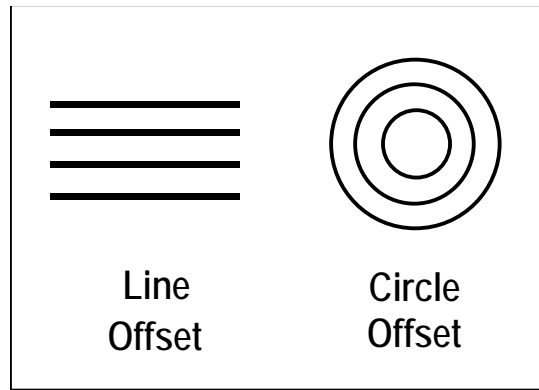

Offset () 9-7

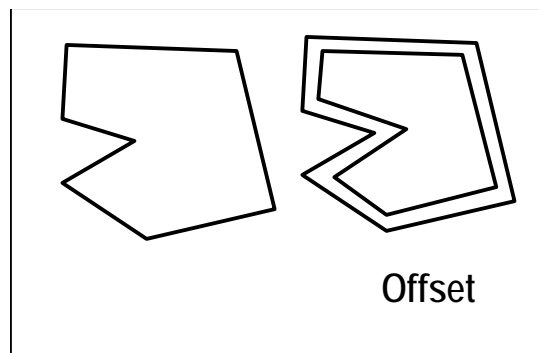

Offset () 9-7

:

Command : Offset
Offset distance or through < through >

Select object to offset :

Side to Offset

Select objects to offset

Enter

تمرين 7-9:

Command : Offset
 Offset distance or through < through> :30
 Select object to offset :
 Side to offset :
 Select objects to offset :
 Command :

Offset

تمرين 7-10:

() 9-7

Offset
 Command : Offset
 Offset distance or through < through> :20
 Select object to offset :
 Side to offset :
 Select objects to offset :
 Side to offset :
 Select objects to offset :
 Command :

ثالثاً: أوامر تغيير خصائص العناصر

التغيير CHANGE

ddmodify ddchprop chprop

```

.                                     :Line
.                                     :Circle
.                                     :Text
.                                     :Block
: "Properties"
change what property color /Elev./layer/Type/thickness
/ / )
/ /
: C
new color <current> < >
by block " "
: - -
3 Green          2 Yellow          1 red
6 Magenta        5 Blue            4 Cyan
7 White
.Z              Elev              "
"Layer        "

```

by layer

" "

"

"Linetype

"

" Thickness

تمرین 7-11:

```

Command : Change
Select object : W
First conner :
First conner :
Select Object :
Properties/ < change point > : P
change what property (color /Elev./Layer /Type/thickness):
New Layer < > :
Command
New Line Type < BAY LAYER
Command

```

التفجير :EXPLODE

Block

Command: explode
Select objects: 1 found

Select objects:

Command:

إصدار الأمر:

- explode •
- .Enter x
- .Modify explode •
- . Modify explode •

القسم Divide

Point Draw

.

.

إصدار الأمر:

- Divide •
- .Enter Div
- .Draw Point Divide •
- . Draw Divide •

:

Command: divide

Select object to divide:

Number of segments

Block

<Number of segments>/Block: b

.

<

>

Block name to insert:

Align block with object? <Y>

Number of segments: 12

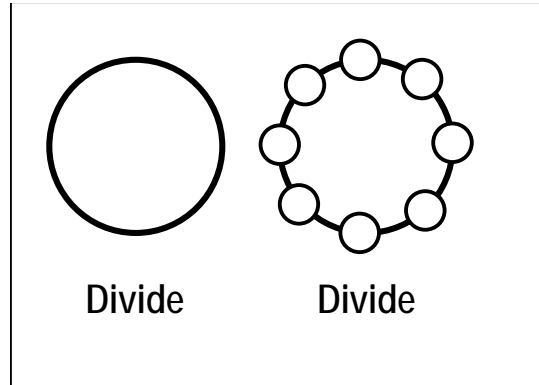

Divide

10-7

شريف 12-7:

```

Command : Ellipse
Arc/Center/<Axis endpoint 1>: 50,50
Axis endpoint 2: 100,50
<Other axis distance>/Rotation: <Ortho on> 100,200
Command: zoom
All/Centr/Dynamic/Extents/Previous/Scale(X/XP)/Window/<Realtime>:a

Command: c
CIRCLE 3P/2P/TTR/<Center point>: 300,200
Diameter/<Radius> <179.2726>: 150
    
```

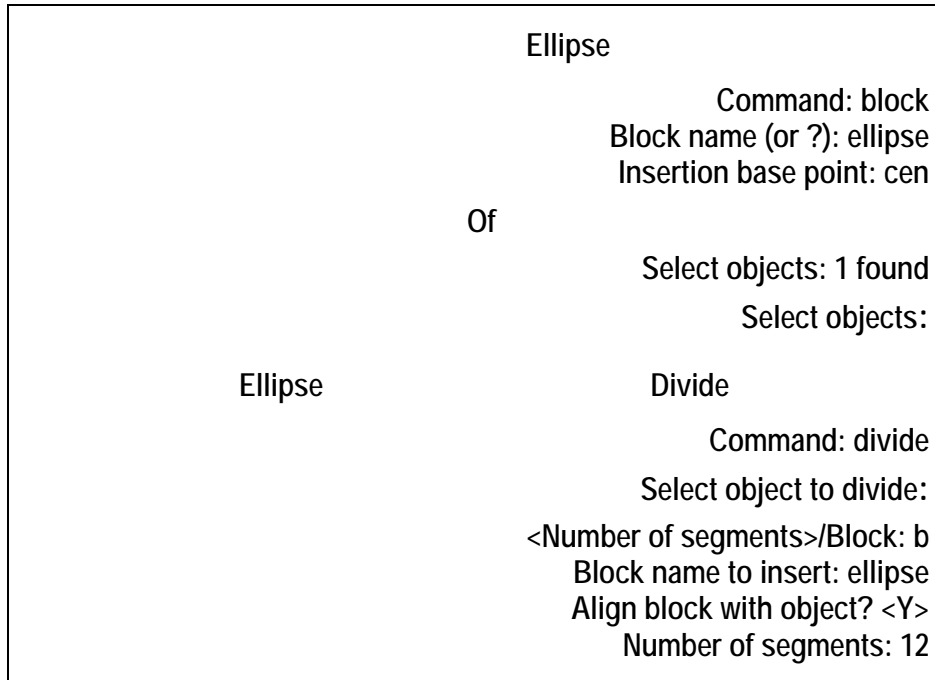

رابعاً: تهذيب الرسوم:

حني الأركان Fillet

=

)

.(

.

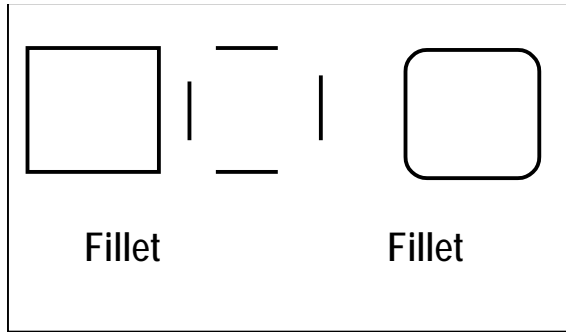

Fillet

11-7

اصدار الامر:

- Fillet •
 - .Enter F
 - .Modify Fillet •
 - . Modify Toolbar Fillet •
- :

Command : Fillet
Polyline / Radius / < select two objects > R

-

R

Enter fillet radius <0>

-

Command :

-

:

Command : Fillet

Select first object :

Select second object :

تمرین 7-13:

```

Command : Fillet
Polyline / Radius / < select two objects > R
Enter fillet radius <0> :3
Command :
Command : Fillet
Select first object : Select point P1 on line L1
Select second object : Select point P2 on line L2
Command :

```

تمرین 7-14:

```

Command : Fillet
Polyline / Radius / < select two objects > R
Enter fillet radius <3> :0
Command :
Command : Fillet
Select first object : Select point P1 on line L1
Select second object : Select point P2 on line L2
Command :

```

Fillet

الشطف CHAMFER

Fillet

Line

polyline

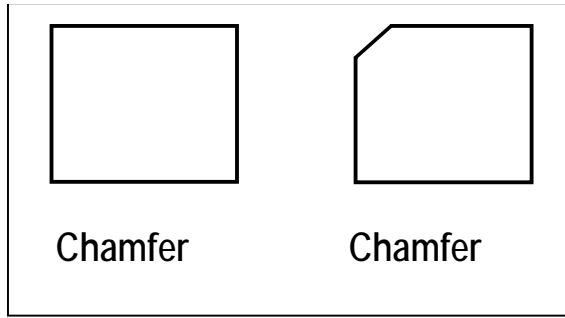

Chamfer

12-7

اصدار الامر:

Chamfer •

.Enter Cha

.Modify Chamfer •

. Modify Toolbar Chamfer •

:

Command : Chamfer
Polyline/ Distance/ <Select first line : D

D -

Enter First chamfer distance < > :

-

Enter second chamfer distance :

-

Command

-

Command : Chamfer

-

Polyline / Distance/ < select first line >

-
select second line :

-
Command :

تمرين 7-15:

Command : Chamfer
Polyline/ Distance/ <Select first line : D
Enter First chamfer distance < 0> :2
Enter second chamfer distance : < 2> :3
Command
Command : Chamfer
Polyline / Distance/ < select first line > Select point P1 on line L1
select second line : Select point P2 on line L2
Command :

قطع الأجزاء الزائدة من عنصر بواسطة عنصر آخر TRIM

Trim

إصدار الأمر:

- Trim •
- .Enter T
- .Modify Trim •
- . Modify Toolbar Trim •

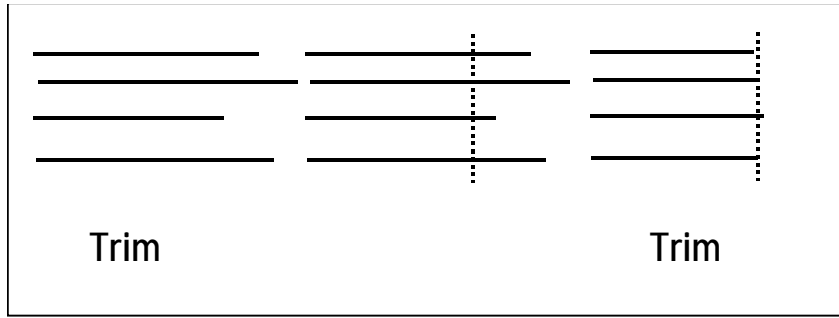

Chamfer

13-7

Command : Trim
Select cutting edge (s)
Select objects :

select objects

0

<select objects to trim >/ undo

0

< select objects to trim> / Undo

0

Command

قربن 7-16:

Command : Trim
Select cntting edge (s)

